

## Test 3 Practice Problems - Physics 2113 - Fall 2016

November 9, 2016

Last Name: \_\_\_\_\_ First name: \_\_\_\_\_

Sec. 1 MWF 8:30am (Rupnik)    Sec. 2 MWF 10:30am (Stadler)    Sec. 3 MWF 12:30pm (Blackmon)

Sec. 4 MWF 1:30pm (Launey)

Sec. 5 MWF 2:30pm (Zuniga-Hansen)

Sec. 6 TuTh 12:00pm (Wilde)

Sec. 7 TuTh 1:30pm (Zuniga-Hansen)

Be sure to write your name and circle your section.

Answer all 5 questions (6 points each) and 3 problems (25 points each).

Please read the questions carefully.

You may use scientific or graphing calculators.

You may detach and use the formula sheet provided at the back of this test. No other reference materials are allowed.

You are strictly forbidden from having access to any electronic communications device during a test. This includes cell phones, pagers, smartphones and tablet or notebook computers. You may not use calculator software on such a device during the test. Any student found with such a device will be assumed to be using it to cheat, and will be reported to the Dean of Students for disciplinary action. Any student who observes another student using such a device during the test should notify the instructor or proctor immediately.

Please use clear, complete sentences if explanations are asked for.

Some questions are multiple choice. You should work these problems starting with the basic equation listed on the formula sheet and write down the steps. Although the work will not be graded, this will help you make the correct choice and be able to determine if your thinking is correct. ***Be sure to mark your final answer clearly.***

On problems that are not multiple choice, you ***must show all of your work.*** No credit will be given for an answer without explanation or work. These will be graded in full, and you are expected to show all relevant steps that lead to your answer.

YOU GET 60 min (1 hr)

**Question 1:** [6 pts] The figure shows 3 particles with the same mass and the same velocity entering a uniform magnetic field (with direction going into the page).

(a) Which statement about the charges of the particles is correct?

- $q_1 > 0$  and  $q_3 < 0$  and  $|q_1| = 2|q_3|$  and  $q_2 = 0$
- $q_1 > 0$  and  $q_3 < 0$  and  $|q_3| = 2|q_1|$  and  $q_2 = 0$
- $q_1 > 0$  and  $q_3 < 0$  and  $|q_1| = |q_3|$  and  $q_2 > 0$
- $q_3 > 0$  and  $q_1 < 0$  and  $|q_1| = 2|q_3|$  and  $q_2 = 0$
- $q_3 > 0$  and  $q_1 < 0$  and  $|q_3| = 2|q_1|$  and  $q_2 = 0$
- $q_3 > 0$  and  $q_1 < 0$  and  $|q_1| = |q_3|$  and  $q_2 < 0$

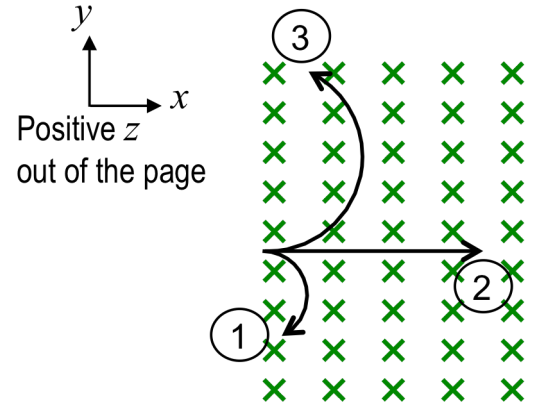

(b) An electric field is applied to the same region in addition to the magnetic field. What is the direction of the electric field if particle 1 moves in a straight line?

- Positive  $x$
- Negative  $x$
- Positive  $y$
- Negative  $y$
- Positive  $z$
- Negative  $z$

**Question 2:** [6 pts] The figure shows two orientations of a current-carrying coil in a uniform magnetic field  $B$ . The magnetic field is going from left to right. The coil is rotated from orientation 2 to orientation 1.

(a) The work done by the magnetic field is

- Positive
- Zero
- Negative

(b) The direction of the torque for orientation 1 is

- Positive  $x$
- Negative  $x$
- Positive  $y$
- Negative  $y$
- Positive  $z$
- Negative  $z$
- Zero

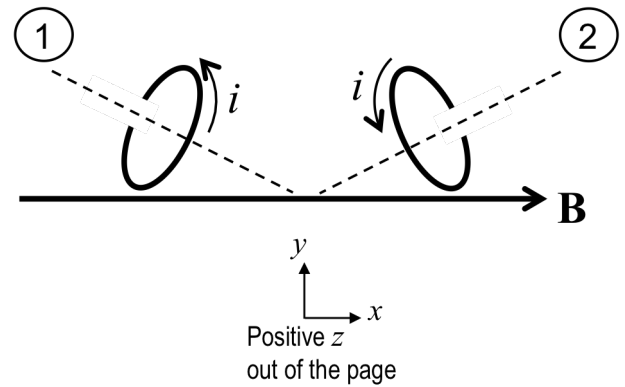

**Question 3:** [6 pts] The figure below shows three cylindrical copper conductors along with their face areas and lengths.

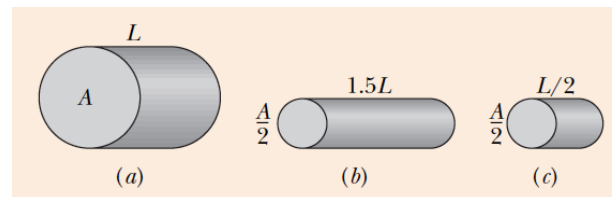

(a) Rank them according to their resistance, greatest first.

- $b > a > c$
- $a > c > b$
- $a = c > b$
- $b > a = c$

(b) Rank them according to the current through them, greatest first, when the same potential difference  $V$  is placed across their lengths.

- $b > a > c$
- $a > c > b$
- $a = c > b$
- $b > a = c$

**Question 4:** [6 pts] The figure shows three long straight, parallel, equally spaced wires with identical currents either going into or out of the page. Rank the wires according to the magnitude of the force on each due to the currents in the other two wires, greatest first.

- $F_a > F_b > F_c$
- $F_c > F_b > F_a$
- $F_a > F_c > F_b$
- $F_b > F_c > F_a$
- $F_a = F_c > F_b$

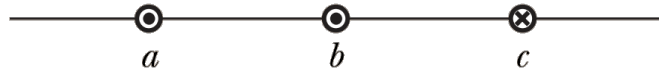

**Question 5:** [6 pts] A capacitor is being charged in an  $RC$  circuit with an ideal battery. The current decreases with time as shown by curve  $a$  in the figure. If the ideal battery is replaced by a real battery of the same emf, which curve will best describe the current?

- $a$         $c$
- $b$         $d$

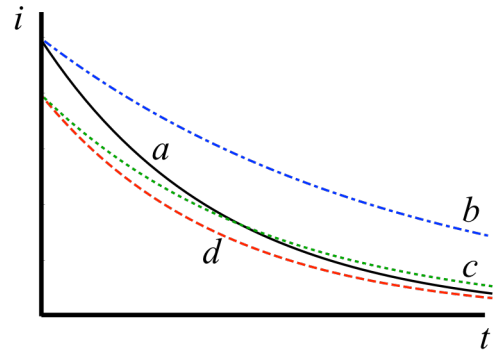

**Problem 1:** [25 pts] Consider the circuit in the figure below, containing ideal batteries and resistors. Each resistor has resistance  $3\Omega$ . Set  $\mathcal{E}_1 = 20.0\text{ V}$ ,  $\mathcal{E}_2 = 5.0\text{ V}$ ,  $\mathcal{E}_3 = 4.0\text{ V}$ ,  $\mathcal{E}_4 = 4.0\text{ V}$ .

(a) (9 points) What is the value and direction of current  $i_1$ ? **Explain.**

(b) (8 points) What is the value and direction of current  $i_2$ ? **Explain.**

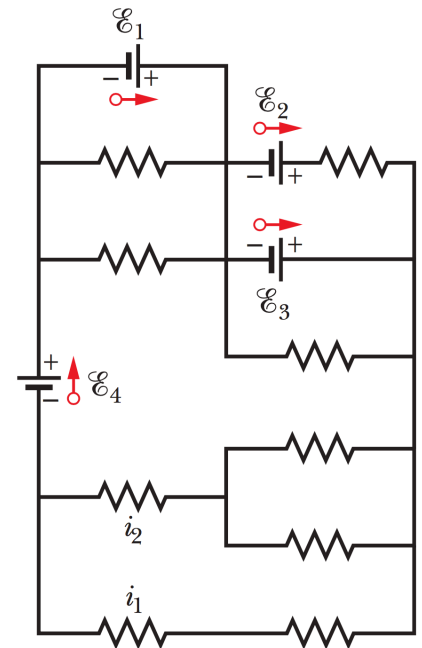

(c) (8 points) What is the power of battery 2? Is the energy being supplied or absorbed by the battery?

**Problem 2:** [25 pts] Consider the figure of the  $RC$  circuit depicted below.

At time  $t = 0$ , the switch  $Sa$  is closed. After a long time:

(a) (4 points) What is the potential difference across  $C$ ?

(b) (4 points) What is the potential difference across  $R_1$ ?

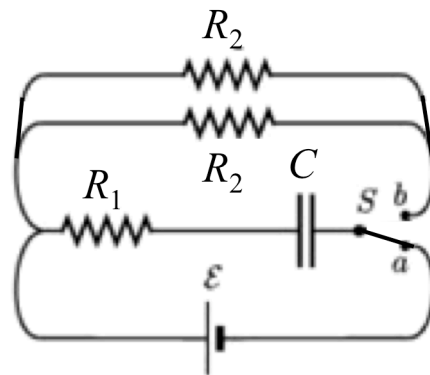

The switch is then moved to  $Sb$ . Immediately after this happens,

(c) (4 points) What is the current through  $R_1$ ?

(d) (4 points) What is the time constant?

(e) (4 points) What is the charge on  $C$  after  $3\tau$ ?

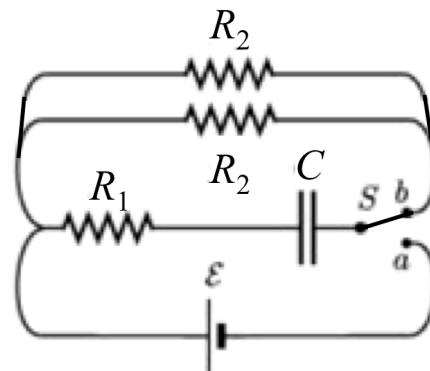

(f) (5 points) What is the current through each  $R_2$  a *long time* after the switch is moved to  $Sb$ ?

**Problem 3:** [25 pts] The current density  $\vec{J}$  inside a long, solid, cylindrical conducting shell of inner radius  $a = 2.3$  mm and outer radius  $b = 4.0$  mm is along the central axis with direction into the page, and its magnitude varies with radial distance  $r$  from the axis according to  $J = J_0 r^2/a^2$ , where  $J_0 = 310$  A/m<sup>2</sup>. The figure below depicts a cross-section of the cylindrical shell.

- (a) (6 points) What is the total current flowing through the above cross-section of the cylindrical shell?

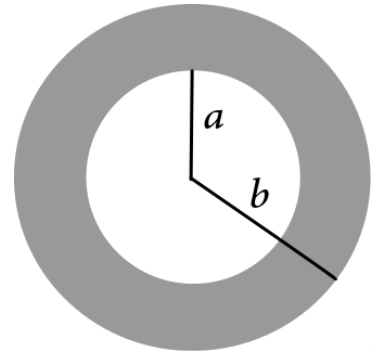

- (b) (6 points) What is the magnitude of the magnetic field at  $r = a/2$ ?

- (c) (6 points) What is the magnitude of the magnetic field at  $r = (a + b)/2$ ?

- (d) (7 points) What is the magnitude of the magnetic field at  $r = b$ ?

**Problem 4:** [25 pts] Two very long straight wires are connected to a semicircle with radius  $R = 20$  cm, and carry current  $i = 2$  A.

(a) (8 points) Using the Biot-Savart law, find the magnetic field at point P in *unit-vector notation* due to the current-carrying semicircle (positive  $x$  to the right, positive  $y$  up, and positive  $z$  out of the page).

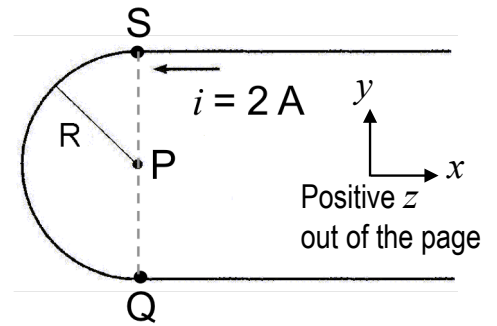

(b) (8 points) Using the Biot-Savart law, find the magnetic field at point P in *unit-vector notation* due to the top wire that starts at point S and extends to infinity. Consider making use of the following indefinite integral:

$$\int \frac{dx}{(x^2+a^2)^{3/2}} = \frac{x}{a^2(x^2+a^2)^{1/2}}$$

(c) (3 points) Using the Biot-Savart law, find the magnetic field at point P in *unit-vector notation* due to the bottom wire that starts at point Q and extends to infinity.

(d) (6 points) What is the total magnetic field at point P in *unit-vector notation*?