

PHYS 7895 Fall 2013
Introduction to Quantum Information Theory
Homework 4

Due Tuesday 12 November 2013, by 5pm in Nicholson 447

(You are allowed to work with others as long as you write down who your collaborators are. Any late assignments will be penalized in the amount of 25% per day late.)

This assignment has a first part and a second part.

First part: Exercises 11.5.1, 11.5.2, 11.5.5, 11.6.2, 11.6.6, 11.7.4, 11.7.5, 11.9.2, 11.9.5, 12.4.1, 12.4.4, 12.5.5, 14.1.6 in **arXiv:1106.1445**

Second part: The exercises below:

1. There is a task known as trade-off coding, where a sender would like to transmit both classical and quantum information to a receiver error-free in the asymptotic limit of many channel uses. You will calculate the boundary of the classical-quantum trade-off capacity region for a qubit dephasing channel (with some assistance). Recall that the qubit dephasing channel accepts an input system A' and outputs a system B according to the following map:

$$\overline{\Delta}_p(\rho) = (1-p)\rho + pZ\rho Z.$$

Suppose Alice prepares states of the following form:

$$\rho^{XAA'} \equiv \frac{1}{2} |0\rangle\langle 0|^X \otimes |\phi_\mu\rangle\langle \phi_\mu|^{AA'} + \frac{1}{2} |1\rangle\langle 1|^X \otimes X^{A'} |\phi_\mu\rangle\langle \phi_\mu|^{AA'} X^{A'},$$

where

$$|\phi_\mu\rangle^{AA'} \equiv \sqrt{\mu} |00\rangle^{AA'} + \sqrt{1-\mu} |11\rangle^{AA'},$$

and $X^{A'}$ is a Pauli bit flip operator acting on register A' . Observe that X is a classical register and A' is a quantum register entangled with A for all μ where $0 < \mu < 1$. The boundary of the capacity region is given by the rate pairs $(I(X; B)_\sigma, I(A)BX)_\sigma$ where

$$\sigma^{XAB} \equiv \overline{\Delta}_p^{A' \rightarrow B}(\rho^{XAA'}).$$

Calculate all rate pairs for the boundary of the region as a function of μ and p . Bonus points if you turn in a plot of the trade-off curve.

2. Suppose that we have an ensemble $\{p_X(x), \rho_x^B\}$. Corresponding to this ensemble, there are weak conditionally typical projectors that we denote as $\Pi_\delta^{B^n|x^n}$ (see Section 14.2). Prove the following operator inequality:

$$\sum_{x^n \in \mathcal{X}^n} p_{X^n}(x^n) \Pi_\delta^{B^n|x^n} \leq \rho^{\otimes n} 2^{n[H(B|X)+\delta]},$$

where $\rho \equiv \sum_x p_X(x) \rho_x$ and the conditional quantum entropy is $H(B|X) = \sum_x p_X(x) H(\rho_x)$.

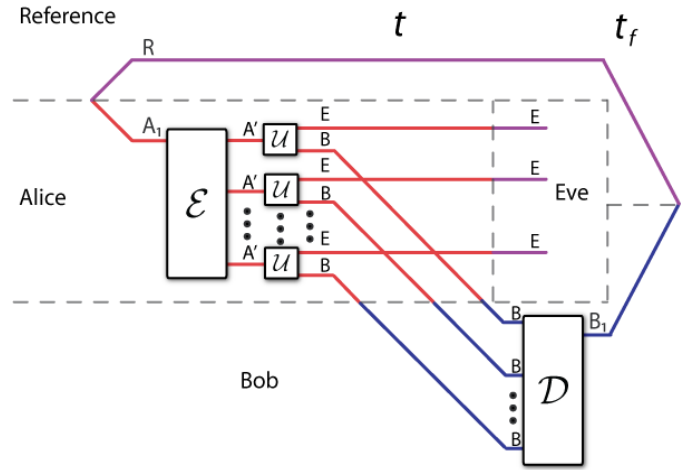

Figure 1: The most general protocol for quantum communication (or, equivalently, entanglement generation). Alice performs an encoding on her A_1 system and then feeds the outputs of the encoder into the inputs of the channels. Bob receives all of the channel outputs and performs some decoding map. If the protocol is good, at the end, Alice and Bob should share a state that is arbitrarily close in trace distance to a maximally entangled state.

3. You will prove the converse part of the quantum capacity theorem in a few steps. Here, we are assuming the existence of a good protocol (in the sense that the trace distance between the actual state resulting from the protocol and the ideal state is close). Then, we prove that the rate at which Alice can transmit quantum information to Bob is bounded above by the coherent information of the channel. That is, we are trying to obtain an upper bound on the quantum capacity of a quantum channel \mathcal{N} . Figure 1 should be helpful for visualizing, and it will be helpful to study the converse proof in Section 19.3.2 for classical communication.

- (a) First argue that it is sufficient to consider upper bounding the rate at which Alice can generate entanglement with Bob, rather than the rate at which Alice can communicate quantum information to Bob. We'll just consider that Alice has the system R in Figure 1.
- (b) Calculate the coherent information of a maximally entangled state with Schmidt rank 2^{nE} (so that E is the rate of entanglement generation).
- (c) Ideally, the protocol generates a maximally entangled state with Bob. In reality, it generates a state at time t_f in Figure 1 that is close to the maximally entangled state. Find an upper bound on the coherent information of the maximally entangled state (one term in the upper bound should be the coherent information of the actual state).
- (d) Use the quantum data processing inequality to find a good upper bound on the bound from part (c).
- (e) Argue that the regularized coherent information of the channel is an upper bound on the bound from part (d). (There is an opportunity for a bonus point here for

those who notice a subtlety with the encoder when obtaining this upper bound.)
If everything adds up, this should be our bound on the quantum capacity.

- (f) Suppose that the channel is an erasure channel. Argue that the coherent information of the channel is an upper bound on the quantum capacity (it actually turns out to be equal to that channel's quantum capacity).