

Practice Test 2 - Physics 2113 - Fall 2016

October 12, 2016

Last Name: _____ First Name: _____

TTH	12:0 pm Wilde Sec. 6	1:30 pm Zuniga-Hansen Sec. 7			
MWF	8:30am Rupnik Sec. 1	10:30am Stadler Sec. 2	12:30pm Blackmon Sec. 3	1:30pm Launey Sec. 4	2:30 pm Zuniga-Hansen Sec. 5

Be sure to write your name and circle your section.

Answer all 3 problems (25 points each) and 5 questions (6 points each).

Please read the questions carefully.

You may detach and use formula sheet provided at the back of this test. No other reference materials are allowed.

You are strictly forbidden from having access to any electronic communications device during a test. This includes cell phones, pagers, smartphones and tablet or notebook computers. You may not use calculator software on such a device during the test. Any student found with such a device will be assumed to be using it to cheat, and will be reported to the Dean of Students for disciplinary action. Any student who observes another student using such a device during the test should notify the instructor or proctor immediately.

Please use clear, complete sentences if explanations are asked for.

Some questions are multiple choice. You should work these problems starting with the basic equation listed on the formula sheet and write down the steps. Although the work will not be graded, this will help you make the correct choice and be able to determine if your thinking is correct. ***Be sure to mark your final answer clearly.***

On problems that are not multiple choice, you ***must show all of your work.*** No credit will be given for an answer without explanation or work. These will be graded in full, and you are expected to show all relevant steps that lead to your answer.

YOU GET 60 min (1 hour)

Question 1: [6 pts] The electric potential at a certain point is given by $V = 2xy^2 - z$, where V is in volts and x and y are in meters.

(i) What is the **x component** of the electric field at point (x, y) ?

- A) $E_x = -4xy + 1$
- B) $E_x = 2y^2 - z$
- C) $E_x = -2$
- D) $E_x = -2y^2$

(ii) What is the **y component** of the electric field at that point?

- A) $E_y = -4xy + 1$
- B) $E_y = -4xy$
- C) $E_y = 2y^2$
- D) $E_y = 0.67xy^3$

Question 2: [6 pts] You move an electron from one equipotential surface to another along one of the four paths shown below. Rank the paths according to the work done by the electric field during the move, from **least to greatest** (taking signs into account).

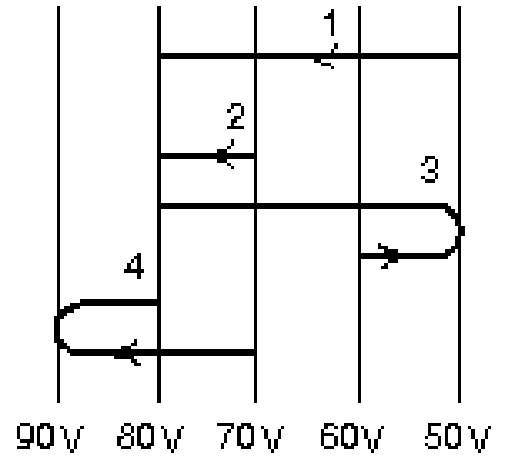

- A) $1 < 2 = 4 < 3$
- B) $2 < 3 < 1 = 4$
- C) $2 = 4 < 3 < 1$
- D) $4 < 3 < 1 < 2$

Question 3 [6 pts] The figure below left shows electric potential V along an x axis. Draw the appropriate plot of the component of the electric field along the x axis, using the figure below right.

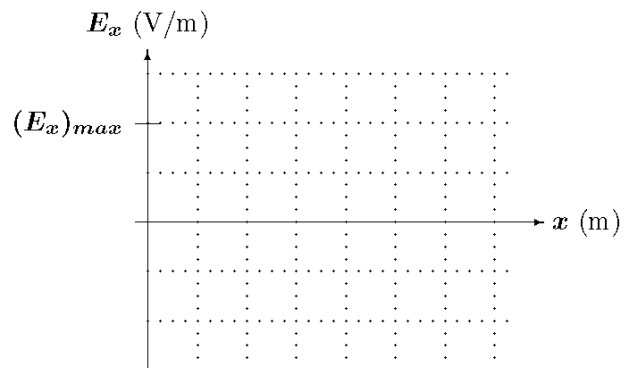
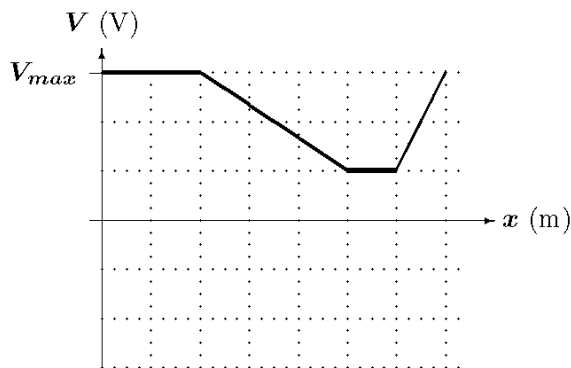

Question 4.A: [6 pts] The figure shows a battery of potential difference V , and three capacitors of capacitance C_1, C_2 , and C_3 , where $C_1 > C_2 > C_3$.

Circle the correct answer below!

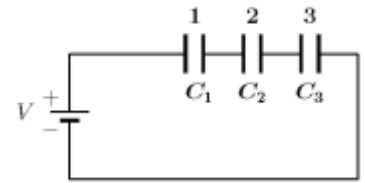

Rank

(a) the potential difference across each capacitor. (b) the magnitude of the charge on each capacitor.

(i) $V_1 > V_2 > V_3$

(i) $q_1 < q_2 < q_3$

(ii) $V_1 > V_2 = V_3 = 0$

(ii) $q_1 = q_2 > q_3 = 0$.

(iii) $V_1 < V_2 < V_3$

(iii) $q_1 > q_2 > q_3$

(iv) $V_1 = V_2 = V_3$

(iv) $q_1 = q_2 = q_3$

Question 4.B: [6 pts] The figure shows a battery of potential difference V , and three capacitors of capacitance C_1, C_2 , and C_3 , where $C_1 > C_2 > C_3$.

Circle the correct answer below!

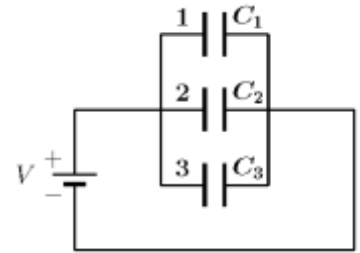

Rank

(a) the **potential difference** across each capacitor? (b) the magnitude of the **charge** on each capacitor.

(i) $V_1 > V_2 > V_3$

(i) $q_1 < q_2 < q_3$

(ii) $V_1 > V_2 = V_3 = 0$

(ii) $q_1 = q_2 > q_3 = 0$

(iii) $V_1 < V_2 < V_3$

(iii) $q_1 > q_2 > q_3$

(iv) $V_1 = V_2 = V_3$

(iv) $q_1 = q_2 = q_3$

Question 5.A: [6 pts] A dielectric slab is inserted between the plates of one of the two identical capacitors in the figure. The battery is connected to the capacitors during the whole process.

Circle **T** if the statement is correct and **F** if it is false.

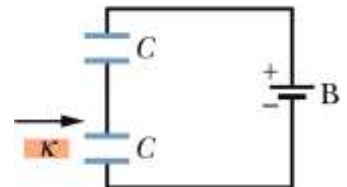

- | | | | |
|----|--|----------|----------|
| A. | The capacitance of the capacitor without dielectric increases. | T | F |
| B. | The charge of the capacitor without dielectric decreases. | T | F |
| C. | The potential of the capacitor without dielectric remains the same. | T | F |
| D. | The capacitance of the capacitor with the dielectric increases. | T | F |
| E. | The charge of the capacitor with the dielectric decreases. | T | F |
| F. | The potential of the capacitor with the dielectric remains the same. | T | F |

Question 5.B: [6 pts] One of the two capacitors A and B, with the same shape and size, has inside a dielectric slab of dielectric constant κ . The capacitors are connected to a battery as shown in the figure. A dielectric slab is then taken out of the capacitor B. The battery is connected to the capacitors during the whole process.

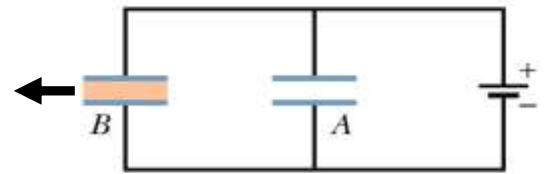

Circle **T** if the statement is correct and **F** if it is false.

- | | | | |
|----|--|----------|----------|
| A. | The capacitance of the capacitor without dielectric increases. | T | F |
| B. | The charge of the capacitor without dielectric decreases. | T | F |
| C. | The potential of the capacitor without dielectric remains the same. | T | F |
| D. | The capacitance of the capacitor with the dielectric increases. | T | F |
| E. | The charge of the capacitor with the dielectric decreases. | T | F |
| F. | The potential of the capacitor with the dielectric remains the same. | T | F |

Problem 1 (show your work) [25 pts]: A thin charged rod of length L lies on the x -axis as shown in the figure. The linear charge density of the rod is $\lambda = -cx^2$, where c is a constant in C/m^3 . Point P is located at distance $L/3$, to the left of the rod.

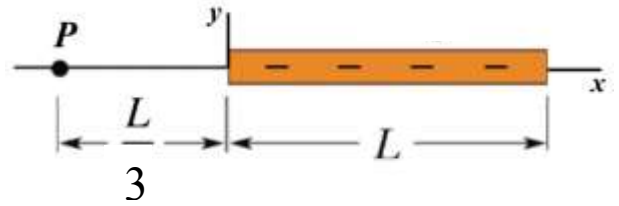

- (a) [5 pts] Write down an expression for the infinitesimal charge dq at a distance x from the origin, in terms of x and the constants.
- (b) [6 pts] Write down the potential dV at point P due to the infinitesimal charge dq at the distance x from the origin, in terms of x and the constants.
- (c) [10 pts] **Write down** the integral, with correct limits, to find the potential at P and **evaluate** it. Express your answer in terms of c , L and fundamental constants.
- (d) [5 pts] How much work would you have to do to bring a point charge q_0 from infinity, where the potential due to the rod is zero, to point P ? Express your answer in terms of c , L and fundamental constants.

Problem 2 (show your work) [25 pts]: Three particles having charges $q_1 = +2.0q$, $q_2 = +6.0q$, and $q_3 = -5.0q$ are positioned in the semi circular array as shown in the picture. The radius of the semi-circle is R .

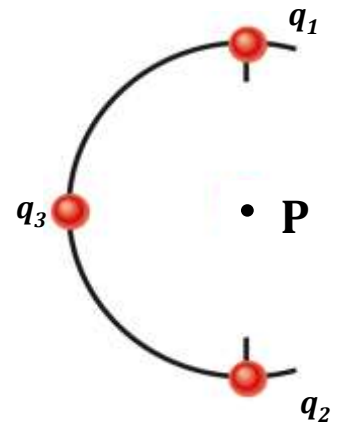

- A. (6 pts) What is the electric potential energy of the three charged particles system? Express your answer in terms of q , R and fundamental constants.
- B. (6 pts) Now you exchange the positions of charges $+q_2$ and $-q_3$. What is the work done by the electric field during that exchange? Express your answer in terms of q , R and fundamental constants.
- C. (8 pts) Find the electric potential at point P, at the center of the circle, due to the three charges, using the positions of charges in part B. Express your answer in terms of q , R and fundamental constants.
- D. (5 pts) If the charge $q = 1.0 \times 10^{-6}$ C and radius $R = 5$ cm, find the values for the quantities in A), B), and C).

Problem 3 (show your work) (25 pts] In the circuit $C_1 = 2 \mu F$, $C_2 = 4 \mu F$ and $C_3 = 9 \mu F$. The battery supplies $V = 15 V$.

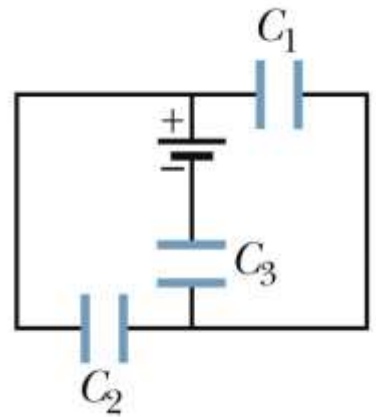

(a) [7 pts] What is the equivalent capacitance of the circuit?

(b) [5 pts] What is the total charge on the equivalent capacitance?

(c) [7 pts] What is the potential difference between the plates of capacitor C_3 ?

(d) [6 pts] What is the charge stored on capacitor C_2 ?